

GESTRA

Non-Return (Check) Valves

For HVAC systems, sanitary applications and industrial technology

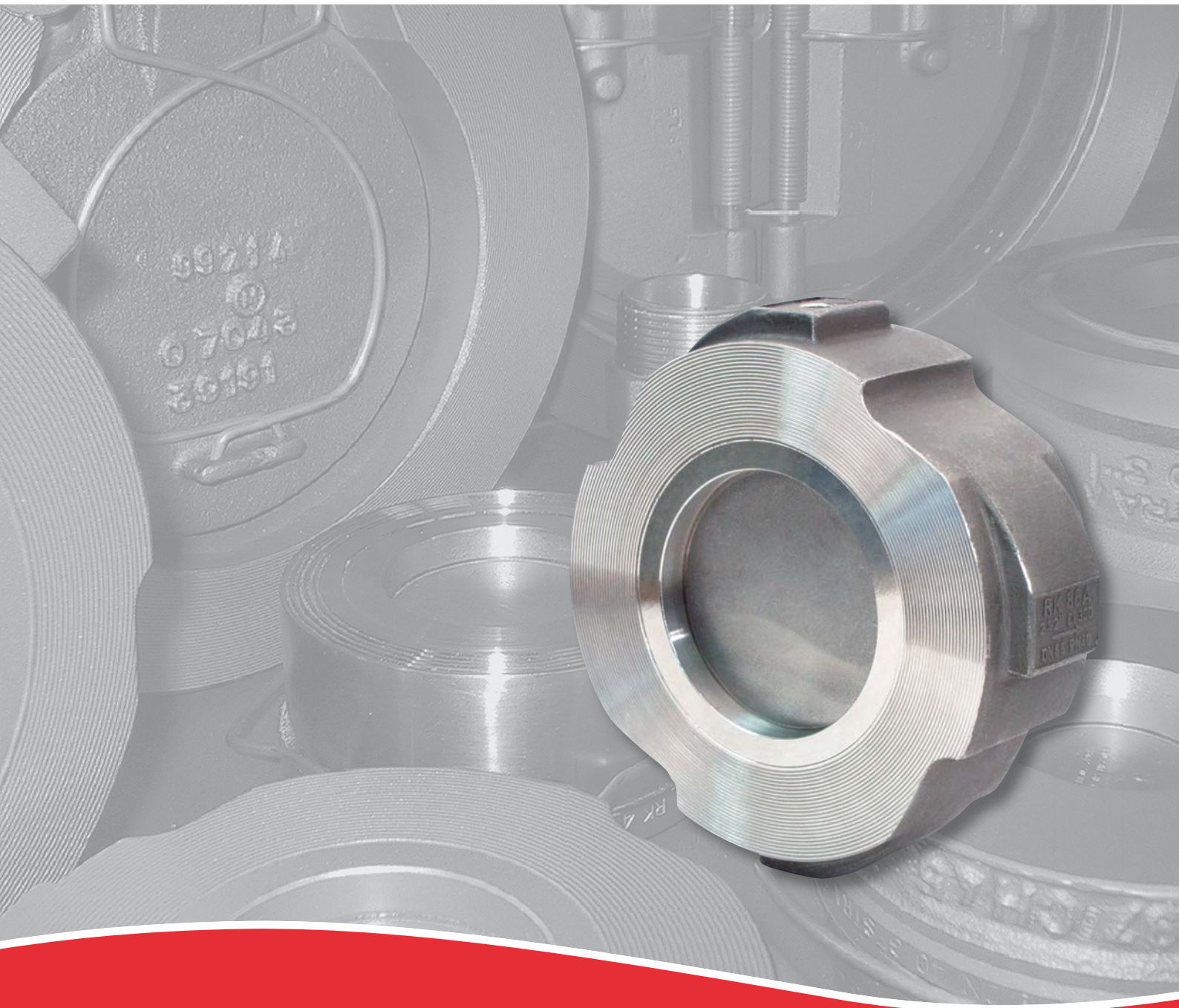



Non-Return (Check) Valves in Steam and Condensate Systems

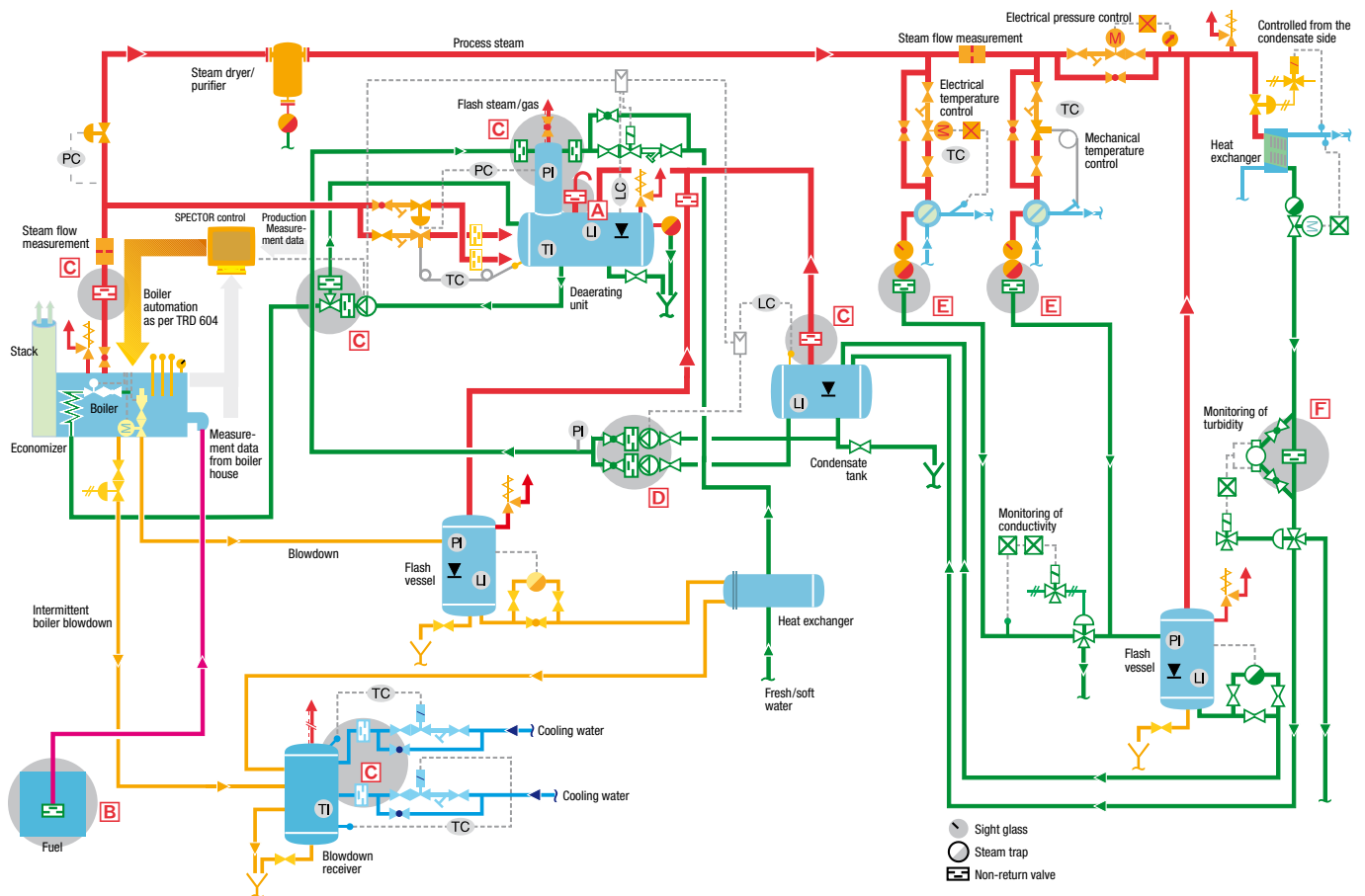

- A Vacuum breaker** prevents vacuum formation and damage to the vessel
- B Foot valve** stops the suction line from running dry when the fuel pump is switched off
- C Preventing backflow** protects against back-flow in the event of malfunction / failure of components

- D Ensuring unidirectional flow** prevents reverse running when pumps arranged in parallel are switched over
- E Non-return valve action for condensate line** prevents banking-up of condensate when the heat exchanger is off, and water hammer within the

- heating surfaces when the plant is started up again
- F Non-return valve** to ensure forced flow

Other applications not shown in the schematic:

- ▶ Vent valve, relief valve
- ▶ Overflow valve

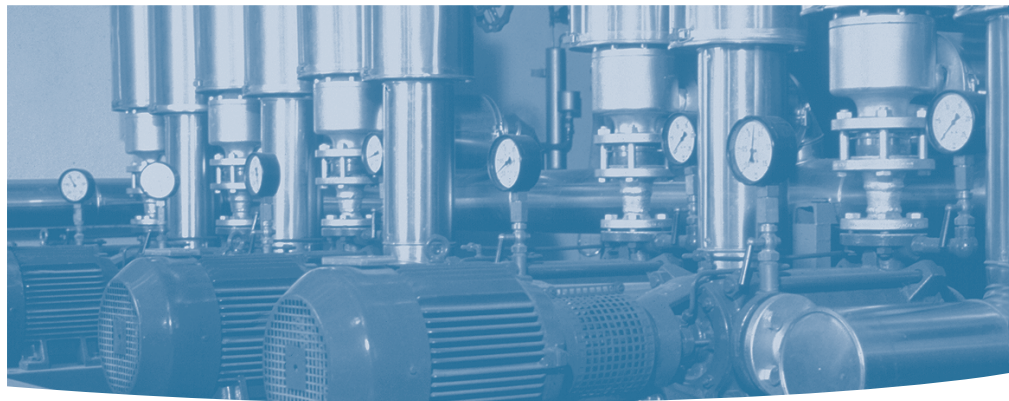

Non-Return (Check) Valves in HVAC Technology

Contents

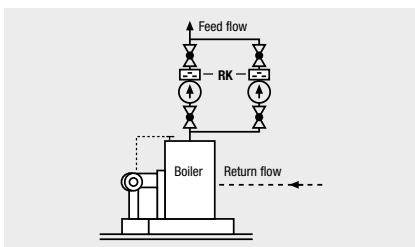

Ensuring unidirectional flow
prevents reverse running when pumps arranged in parallel are switched over

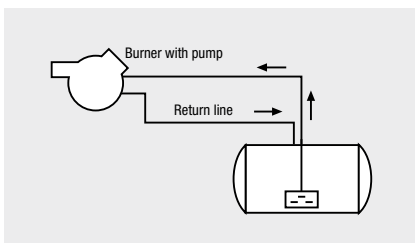

Foot valve
stops the suction line from running dry when the pump is switched off

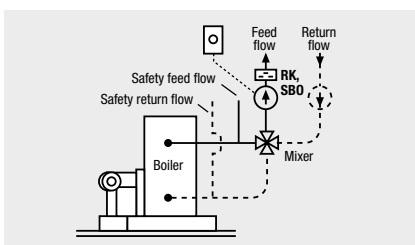

Gravity circulation check
prevents circulation caused by gravity

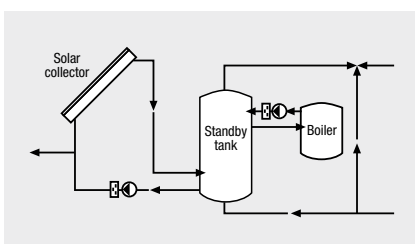

Preventing backflow
protects the pump against backflow after it is switched off

GESTRA Gravity Circulation Checks SBO	4–5
GESTRA DISCO® Non-Return Valves	6–9
GESTRA DISCO® Non-Return Valves RK	10–13
GESTRA DISCO® Non-Return Valves RK 86 and 86 A	14–15
GESTRA DISCOCHECK® Dual-Plate Check Valves BB	16–21
GESTRA NAF Check Valves	22–23
GESTRA DISCOCHECK® Swing Check Valves CB and WB	24–25
Selection and Sizing of Check Valves	26
Application Examples	27



GESTRA Gravity Circulation Checks SBO

These check valves are used for preventing gravity circulation in heating and hot-water systems.

With its three SBO types, GESTRA offers the right gravity circulation check for every pump connection. The SBO 11 and SBO 21 valves can replace the isolating valve in the supply line. These valves remain in the line should the pump have to be removed or exchanged. The benefit: the plant need no longer be completely emptied.

Functional principle

Gravity circulation checks function like non-return valves. If a pressure difference is generated, i.e. if the pressure up-stream the closing element is stronger than the pressure down-stream of the element, then the gravity circulation check opens. Depending on how strong the volume flow of the water is, the valve opens either partly or completely.

As soon as the opening force decreases and the closing force is greater, the gravity circulation check closes again.

Gravity circulation check SBO 11
 DN 1", 1 1/4", PN 6
 ▶ Valve inlet with collar for fitting a union nut
 ▶ Valve outlet with female thread



Gravity circulation check SBO 21
 DN 1", 1 1/4", PN 6
 ▶ Valve inlet with collar for fitting a union nut
 ▶ Valve outlet with male thread



Gravity circulation check SBO 31
 DN 3/4", 1", 1 1/4", PN 6
 ▶ Valve inlet with female thread for direct connection to circulating pump
 ▶ Valve outlet with male thread

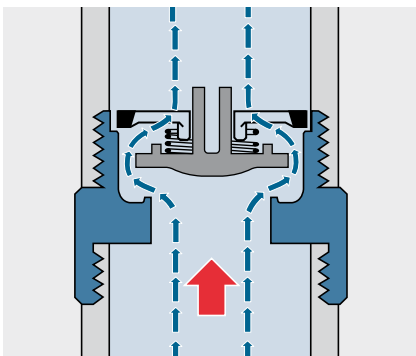

Pump running, normal operation

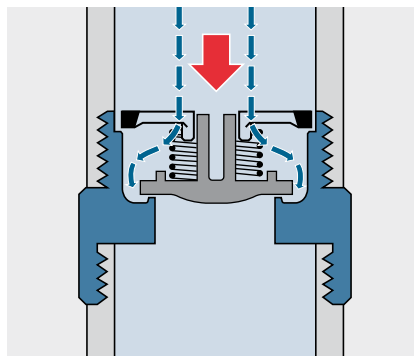

Pump stationary, SBO preventing gravity circulation

Non-Return (Check) Valves

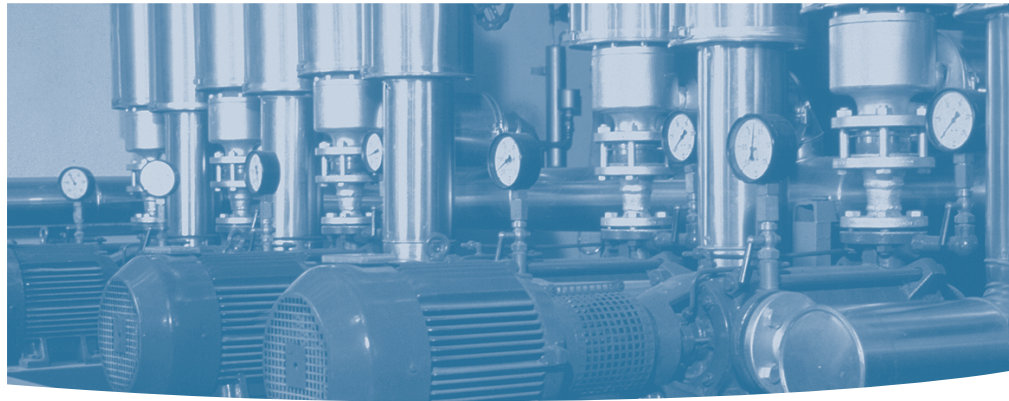

Connections ▶

GESTRA gravity circulation checks are available with connections meeting all installation requirements. Available designs with either male or female thread for PN 6, 1–2" BSP

Spring opening pressure ▶

The spring forces are adapted to the special use of the valve as gravity circulation checks and positively prevent gravity circulation

Shut-off ▶

The use of plastic valve cones ensures quiet operation. The SBO 11 and SBO 21 valves in addition are supplied with a seat gasket of EPDM

Tightness ▶

The choice of materials and the careful manufacture ensure tight closure of the valve cone

Guiding ◀

The guide resists wear and is corrosion-resistant. Jamming and canting of the valve cone are excluded

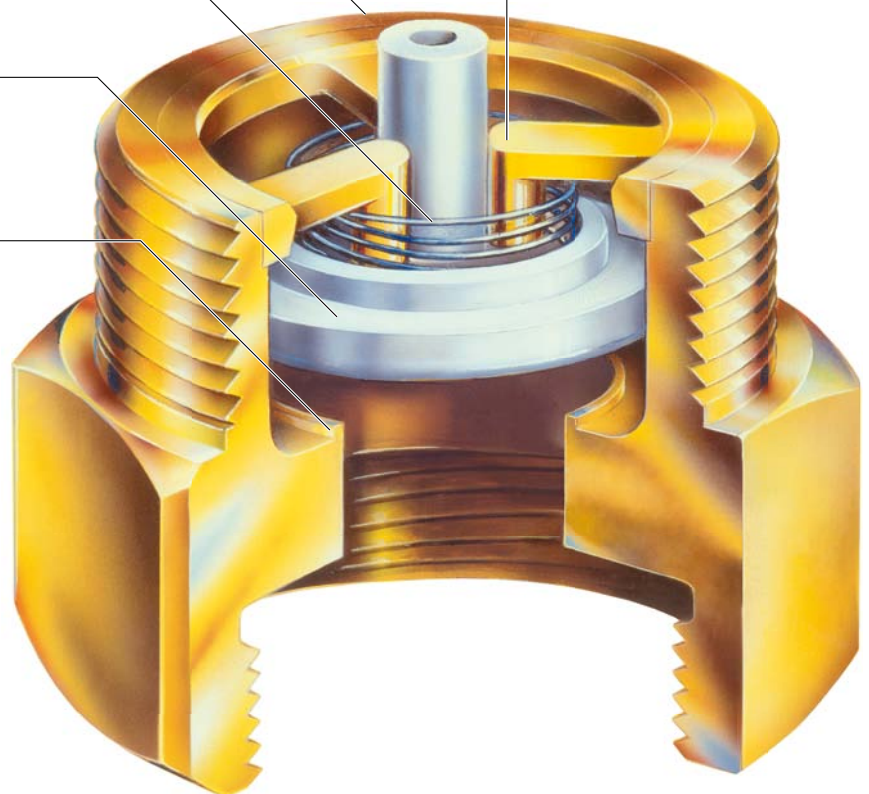



GESTRA DISCO® Non-Return Valves

Today GESTRA can look back with pride on one hundred years of experience in valve manufacture. The company offers a broad range of DISCO® non-return valves tailored to fulfil the most diverse of applications and customer requirements.

All valves are made of diverse materials to meet particular demands, and the individual valve components are optimally coordinated with each other.

Through this ideal mixture of different components in the range of standard valves, the best valve can be delivered for almost every application. Here it does not matter whether a thermally critical application must be safeguarded, or whether a

non-return valve must be designed for operation in oxygen, for example. It is even possible to manufacture the DISCO® valve, which has proven its worth a million times over, in a special material to answer specific needs. All GESTRA non-return valves are of the wafer type and have extremely short overall lengths. Thanks to their excellent design and hydrodynamic features, these valves offer clear advantages over conventional types:

- ▶ Compact design
- ▶ Low weight
- ▶ Mounting in any position
- ▶ Low installation costs
- ▶ Wide choice of materials
- ▶ Space-saving stockkeeping
- ▶ Safe operation of industrial plants
- ▶ Low pressure drop



The name GESTRA is a guarantee of high manufacturing quality for the GESTRA DISCO® non-return valves.

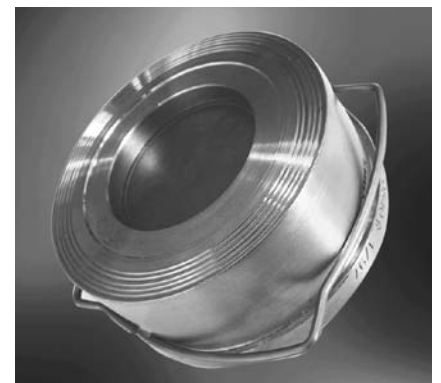

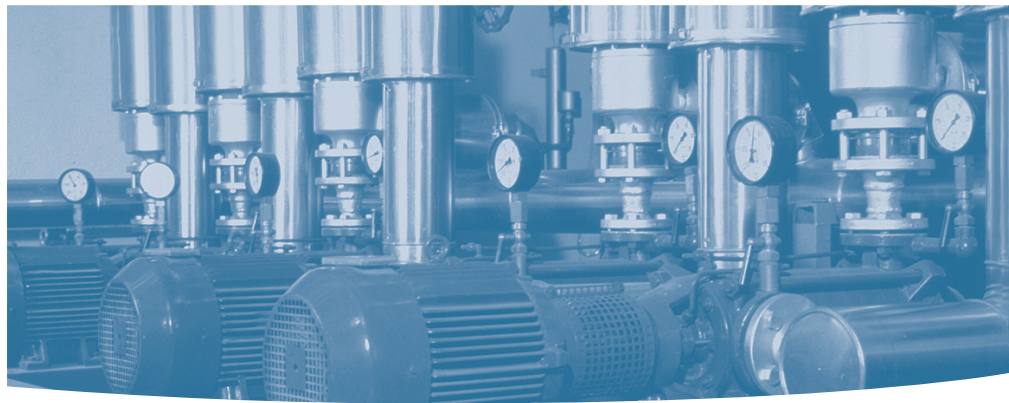

Functional principle

The spring-assisted DISCO® non-return valve opens when the opening force exceeds the closing force. The opening force depends on the pressure or the volume flow, and the closing force on the tension of the closing spring, on the closing weight, on the installation position and the size of the non-return valve.

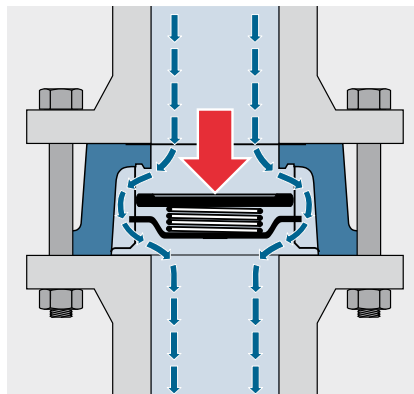

GESTRA DISCO® non-return valve in the fully open state

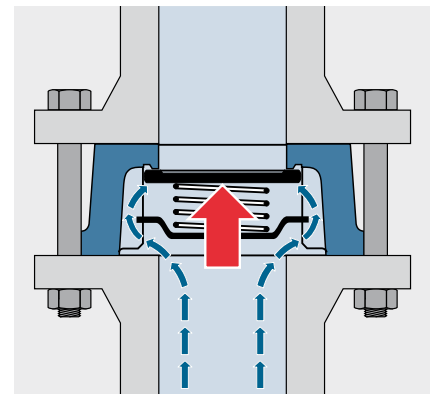

GESTRA DISCO® non-return valve in the closed state

Installation

GESTRA DISCO® non-return valves can be installed in any position, with the sole exception of the valves supplied without a spring. These valves can only be installed in vertical lines with upward flow.

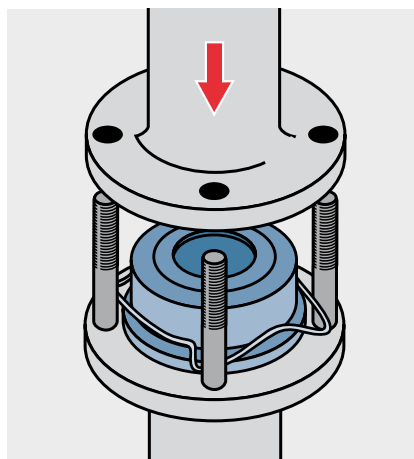

GESTRA DISCO® non-return valve with spiral centering, DN 15–100 (1/2–4")

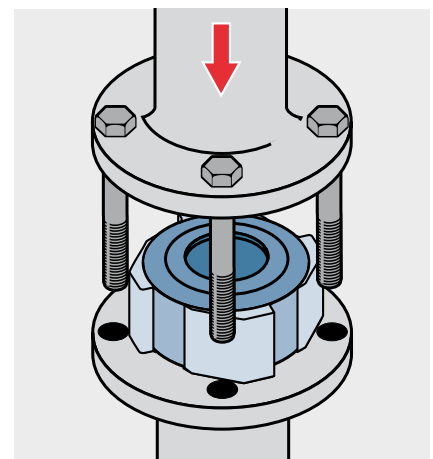

GESTRA DISCO® non-return valve with self-centering body, DN 15–100 (1/2–4")



GESTRA DISCO® Non-Return Valves

Short overall length, low weight

Valves with short face-to-face dimensions reduce the weight and size of a plant. As the figure below demonstrates, the overall length of a GESTRA non-return valve is only 1/8 that of a conventional non-return valve. The overall lengths comply with DIN EN 558, series 49 and 52 (K4/K5).

The wafer design drastically reduces the weight in comparison with conventional valves. A GESTRA non-return valve of stainless steel in DN 200 weighs 23 kg, whilst the weight of the corresponding conventional type is 120 kg!

Connections of your choice

For flanges to DIN EN 1092-1, form B1/B2/D/F, to ASME RF/RJ, or to works standards

Materials

DIN/EN and ASTM:

- ▶ Hot-pressed brass
- ▶ Special brass
- ▶ Cast bronze
- ▶ Grey cast iron
- ▶ High-temperature ferritic cast steel
- ▶ Stainless steel / cast steel
- ▶ Austenitic steel / cast steel
- ▶ High-temperature austenitic cast steel
- ▶ Hastelloy C

Special materials available on request.

Tight shut-off

GESTRA non-return valves are tested according to DIN EN 12266-1, with water or air as the medium. This corresponds to the outdated DIN 3230, part 3, test specifications "BN" (tightness test with water) and "BO" (tightness test with air).

For valves with a soft seat, values corresponding to leakage rate A are achieved (BN1/BO1).

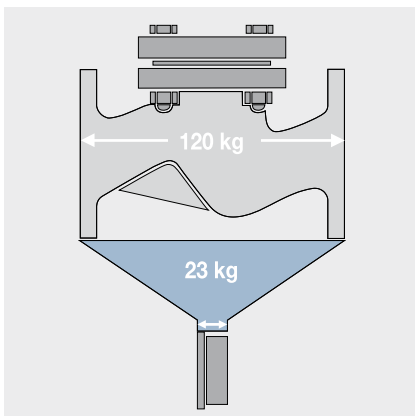

Nominal width DN	mm	in	Overall length L in mm	
			Series 49	Series 52
15		1/2	16	25
20		3/4	19	31.5
25		1	22	35.5
32		1 1/4	28	40
40		1 1/2	31.5	45
50		2	40	56
65		2 1/2	46	63
80		3	50	71
100		4	60	80
125		5	90	110
150		6	106	125
200		8	140	160

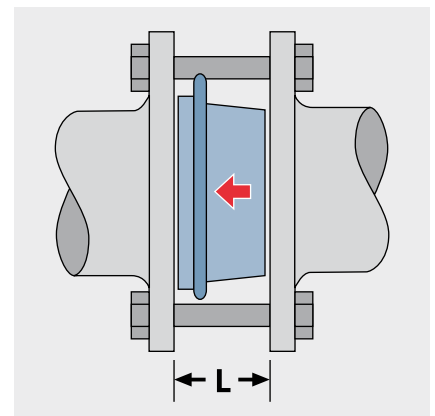

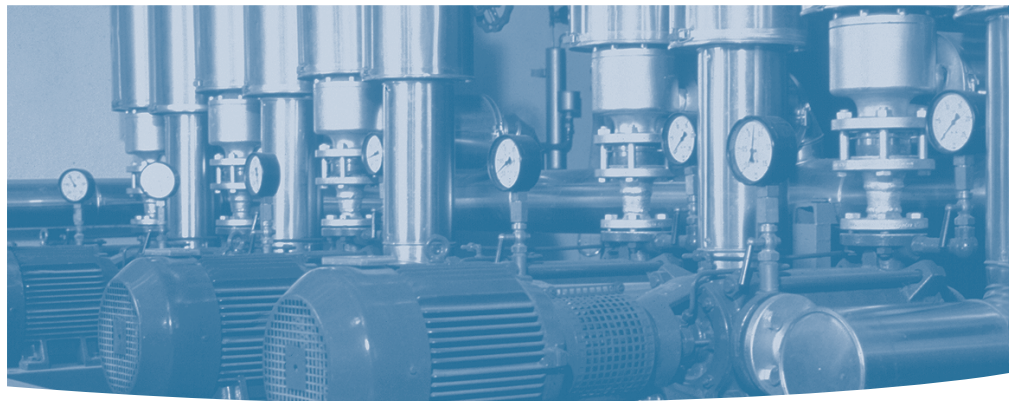

Valves with soft seat

Non-return valves provided with a metallic disc are also available on request with a soft seat made of:

- ▶ EPDM (ethylene-propylene rubber) suitable for water and steam, -40 to +150 °C.
- ▶ FPM (fluoro-rubber) for mineral oil and gases, -25 to +200 °C.
- ▶ PTFE (Teflon) for corrosive media, -190 to +250 °C.

CE

The products comply with the requirements of the EU Pressure Equipment Directive 97/23/EC. Classified for use with fluids of group 1 and/or 2 (dangerous and non-dangerous substances). Some nominal sizes fall under the exception rule (Article 3.3) and therefore may not bear any CE marking.

For further information, please see our Price List.

Valve type	Nominal sizes DN												
	15 1/2"	20 3/4"	25 1"	32 1 1/4"	40 1 1/2"	50 2"	65 2 1/2"	80 3"	100 4"	125 5"	150 6"	200 8"	
Heating, venting, sanitary and air-conditioning	RK 70	Hot-pressed brass / valve disc of plastic For flanges PN 6 / 10 / 16 Heating installations up to 100°C, compressed-air systems								Grey cast iron / plastic PN 6			
	RK 71	Hot-pressed brass / valve disc of austenitic steel For flanges PN 6 / 10 / 16 Heating installations, higher temperatures								Please order these sizes as RK 41			
	RK 41	Special brass / valve disc of austenitic steel PN 6 / 10 / 16 Liquids, gases, vapours / for industrial and heating plants								Grey cast iron PN 6 / 10 / 16			
	RK 44	Cast brass / valve disc of austenitic steel PN 6 / 10 / 16 Liquids, gases, vapours								Grey cast iron / cast bronze PN 6 / 10 / 16			
	RK 44S	Cast bronze PN 6 / 10 / 16 Seawater and drinking water								Cast bronze PN 6 / 10 / 16			
	RK 76	Chromium steel / valve disc of austenitic steel PN 6 / 10 / 16 / 25 / 40 – ASME Class 150 / 300 RF Liquids, gases, vapours / for industrial and heating plants											
	RK 86	Stainless steel / valve disc of austenitic steel PN 6 / 10 / 16 / 25 / 40 – ASME Class 150 / 300 RF Liquids, gases, vapours / high corrosion resistance								Steel / cast steel PN 10 / 16 / 25 / 40			
	RK 86A	Austenitic steel PN 6 / 10 / 16 / 25 / 40 – ASME Class 150 / 300 RF Corrosive liquids, gases, vapours, acids, alkalis								Aust. steel / aust. cast steel PN 10 / 16 / 25 / 40			
	RK 26A	Austenitic steel PN 10 / 16 / 25 / 40 – ASME Class 150 / 300 RF Corrosive liquids, gases, vapours, acids, alkalis								Please order these sizes as RK 86A			
	RK 29A	Austenitic steel PN 63 / 100 / 160 / 250 / 320 / 400 – ASME CL. 400 – 2500 Liquids, gases, vapours / high corrosion resistance								Austenitic steel			
Industrial Technology	RK 49	High-temperature austenitic cast steel PN 63 / 100 / 160 Liquids, gases, vapours at high temp. (up to 450°C)						High-temperature ferritic cast steel PN 63 / 100 / 160					
	RK 16C	Hastelloy C or equivalent nickel alloys PN 10 / 16 / 25 / 40 Particularly corrosive media								On request			

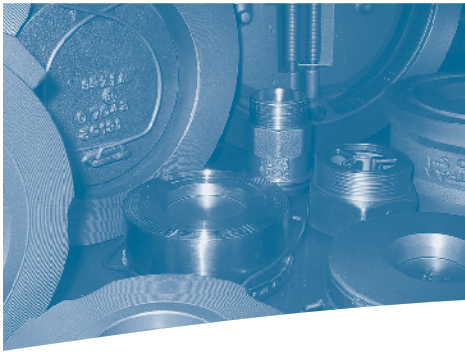

GESTRA DISCO® Non-Return Valves RK

Valve types

For the sector of heating, venting and air-conditioning, various non-return valves are available for a wide range of requirements. The RK 70 is a low-noise non-return valve, so you see what your heating system gives you but do not hear it. Quality at low cost is offered by the RK 71, whilst the RK 41 is our universal and flexible valve satisfying diverse requirements in HVAC technology. Or do you need a valve for a drinking water system, in which no brass may be used? Or one suitable for low temperatures? Then you should take the RK 44. The RK 44S is recommended for seawater, drinking water and swimming-pool water. And if the call is for a valve which must be screwed into the pipe – a solution is provided even for this case with the MB 14.

RK 70
with spiral centering
PN 6, body material
hot-pressed brass,
valve disc of PPO



RK 71
with spiral centering
PN 6 to PN 16, body
material hot-pressed
brass, valve disc of
austenitic steel



RK 41
with spiral centering
PN 6 to PN 16, body
material special
brass, valve disc of
austenitic steel



RK 44
with spiral centering
PN 6 to PN 16, body
material bronze, valve
disc of austenitic steel



RK 44S
with spiral centering
PN 6 to PN 16. Body
material: bronze.
Valve disc: bronze



MB 14
Screwed 1/2–2" BSP,
body material hot-
pressed brass, valve
disc of austenitic steel



Non-Return (Check) Valves

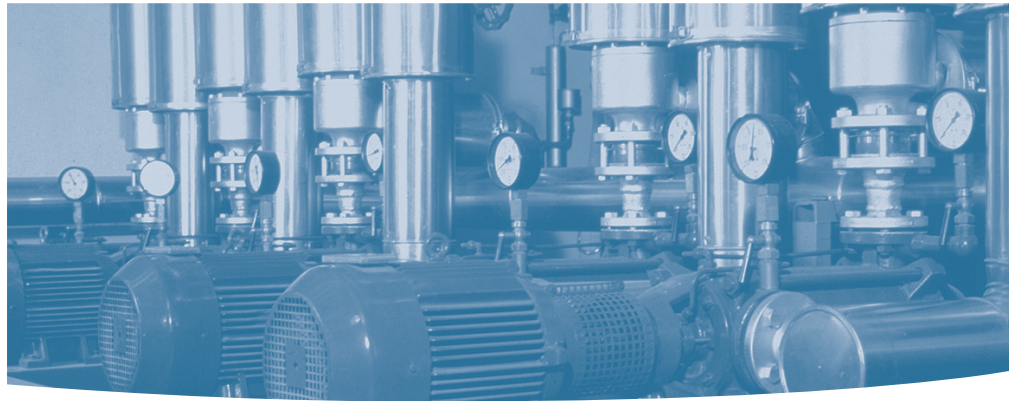

Spring cap ▶

The special shape always guarantees a centralized positioning of the spring.
Material: austenitic steel

Guiding ▶

Four guide ribs are used to ensure low-wear operation. From DN 125 (5"), the valve cone is guided by a spindle/sleeve arrangement

Centering ▶

Serves as installation aid for centred mounting

Valve disc ▶

Austenitic steel, metal-to-metal seat.
RK 41 and RK 44 can alternatively be provided with a soft seat

Springs ▶

Using different springs for the RK 41 and RK 44 permits variation of the opening pressure to meet the operating requirements

Tightness ▶

The degree of tightness lies well within the tolerances permitted in DIN EN 12266-1

Body ▶

Wafer-type valve for DIN/EN, BS or ASME flanges

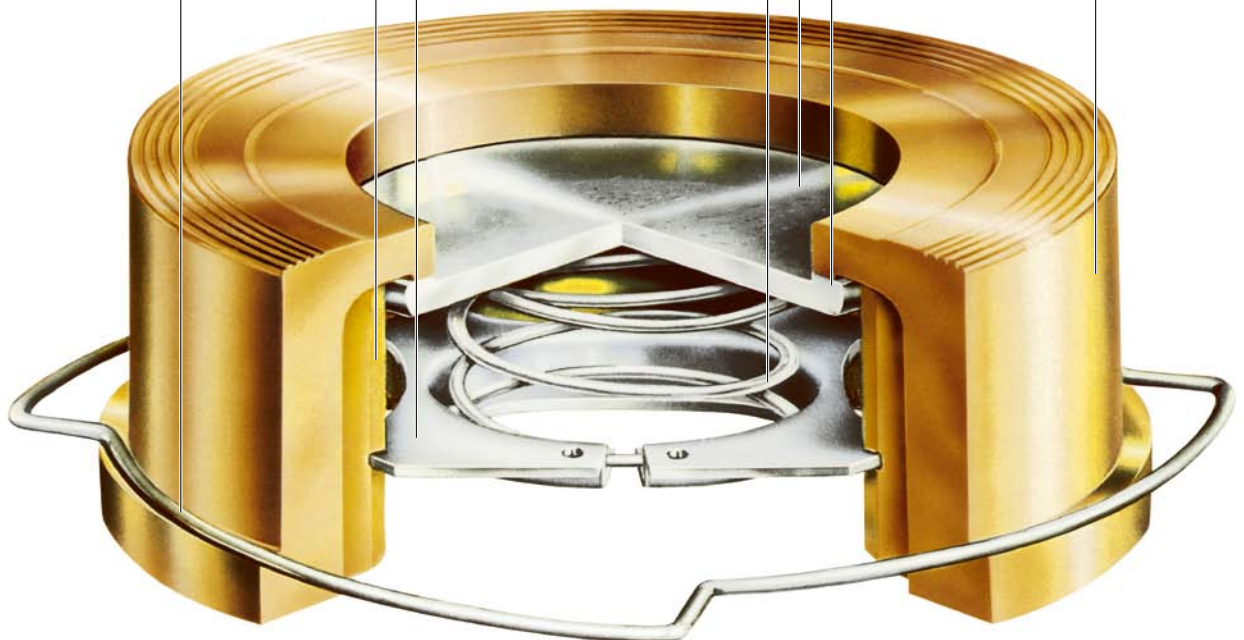

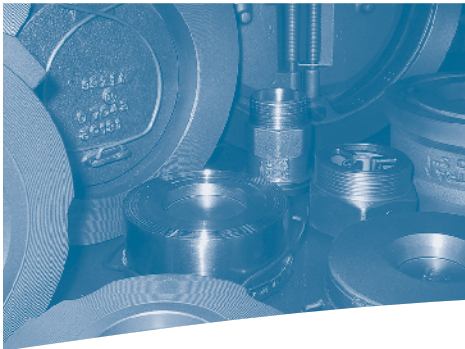

GESTRA DISCO® Non-Return Valves RK

For industrial plants, GESTRA offers a broad spectrum of non-return valves which are designed for diverse pressure ratings and media.

For pressures from PN 6 to PN 40, the RK 86/86A can be used, for example – and for the pressure range PN 10–40 the RK 16C of Hastelloy. The RK 49 covers the pressure ratings up to PN 160 and the RK 29A the pressure ratings PN 63–400.

Depending on the medium flowing through the piping of your installation, a valve is then selected from the most suitable material. For neutral liquids or gases, valve ranges are available in the materials brass, bronze, steel and chromium steel. In the case of corrosive vapours and gases, acids and alkalis, the versions of austenitic steel and Hastelloy are used. For special requirements, e.g. in the foodstuff industry, at low temperatures or for applications with drinking water, valve ranges of cast bronze, austenitic steel and Hastelloy C are available.

Special features:

- ▶ Springs for low opening pressures
- ▶ Springs for reduced closing times
- ▶ Springs for applications at high temperatures
- ▶ Soft seats
- ▶ Antistatic connection
- ▶ Pickled, free of oil and grease / silicone
- ▶ Special connections
- ▶ Blind drilling

RK 86 und 86A
with patented universal centering.
As standard unit, it fits between flanges for PN 6–40, Class 150 / 300 and also between BS10 flanges. Body material: stainless (RK 86) or austenitic steel (RK 86A). Valve disc: austenitic steel



RK 76

The standard valve completely of stainless steel at the price level of carbon steel



RK 26A

with self-centering body, PN 10 to 40, DN 15 to 100 (1/2 to 4"). Facings suitable for counterflanges to ASME 150 RF, ASME 300 RF, tongue or male flanges to DIN EN 1092. Material: austenitic steel



RK 29A

with self-centering body, PN 63 to 160 (PN 400 on request), Class 400 to 1500 (Class 2500 on request). Material: austenitic steel



RK 49

with spiral centering, for high temperatures, PN 63 / 100 / 160, DN 15 to 200 (1/2 to 4"). Material: high-temperature austenitic cast steel / high-temperature cast steel



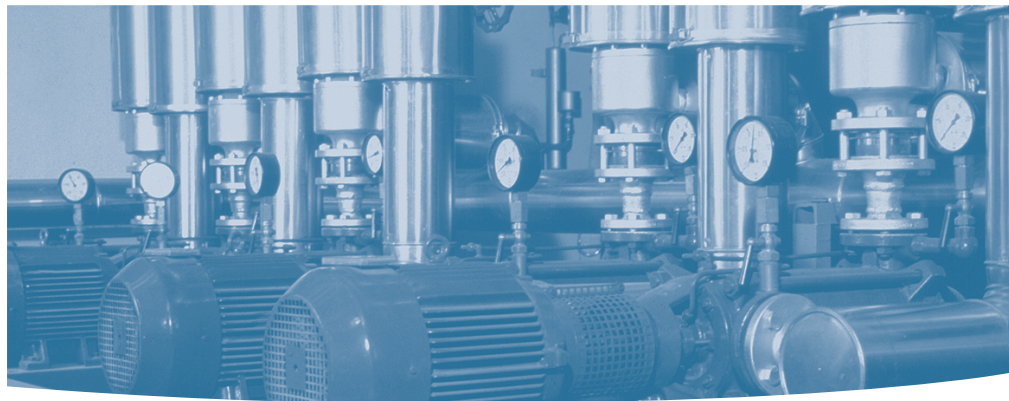

Spring cap ▶

The special shape always guarantees a centralized positioning of the spring.
Material: austenitic steel

Guiding ▶

Four guide ribs are used to ensure low-wear operation. From DN 125 (5"), the valve cone is guided by a spindle/sleeve arrangement

Centering ▶

With special centering ring or, for the RK 86 and RK 86A, centering through the body

Valve disc ▶

Austenitic steel, metal-to-metal or soft seat

Springs ▶

Different springs permit variation of the opening pressure to meet the operating requirements. Material: austenitic steel, Nimonic or Inconell

Tightness ▶

Thanks to special machining, the degree of tightness lies well within the tolerances permitted in DIN EN 12266-1

Antistatic connection ▶

Standard for RK 86 and RK 86A

Body ▶

Diverse materials and two overall lengths, complies with DIN EN 558, series 49

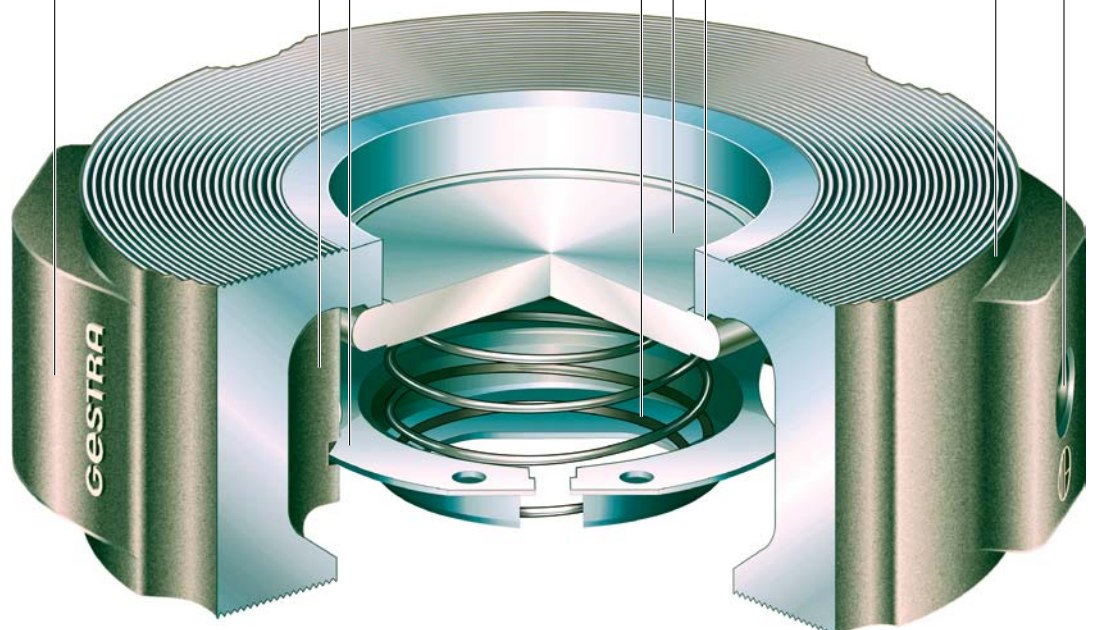

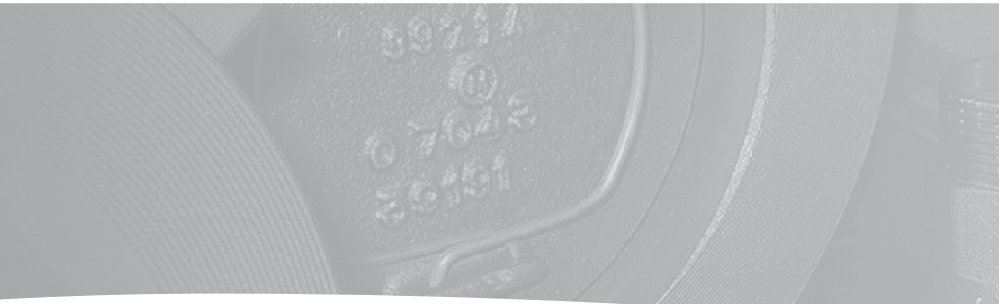

GESTRA DISCO® Non-Return Valves RK 86 and 86 A

Our experience gives you the quality, our visions give you the innovative energy. On this foundation, GESTRA has developed a non-return valve for industrial applications that combines many requirements in a single valve – and therefore not only fulfils but also far surpasses your wishes and expectations.

Patented centering

The patented centering mechanism of the RK 86/86A (patents pending) functions directly through the body itself. It has four integrated guide ribs arranged so that, independently of the flange standard, the valve disc of the RK 86/86A always lies against two of the guide ribs. The non-return valves of other manufacturers are fitted with only three guide ribs at best, which means that the valve disc, depending on installation, usually only has contact with one of them.

All international standards

Whether for DIN/EN, ASME or BS flange, this new DISCO® non-return valve is prepared for all international standards.

Low wear

Since the new RK 86/86A lies on not just one but **two** guide ribs, the rate of wear is halved – making for long service life. What is more, jamming and canting of the valve disc is then hardly possible. The risk of failure in your plant is thus reduced to a minimum.

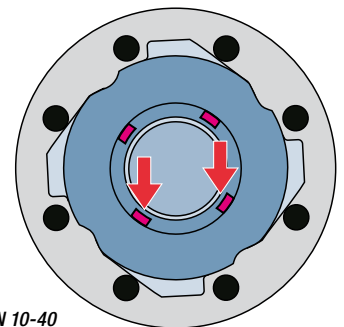

DIN/EN PN 10-40

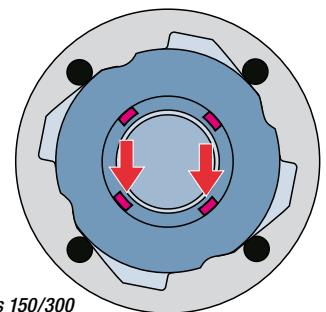

ASME Class 150/300

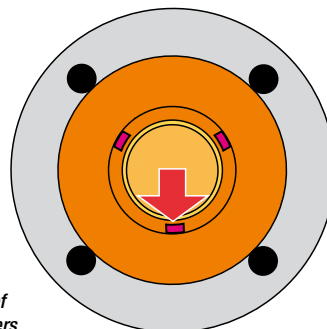

Non-return valves of
OTHER manufacturers

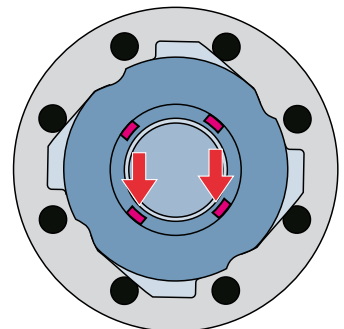

BS 10 J

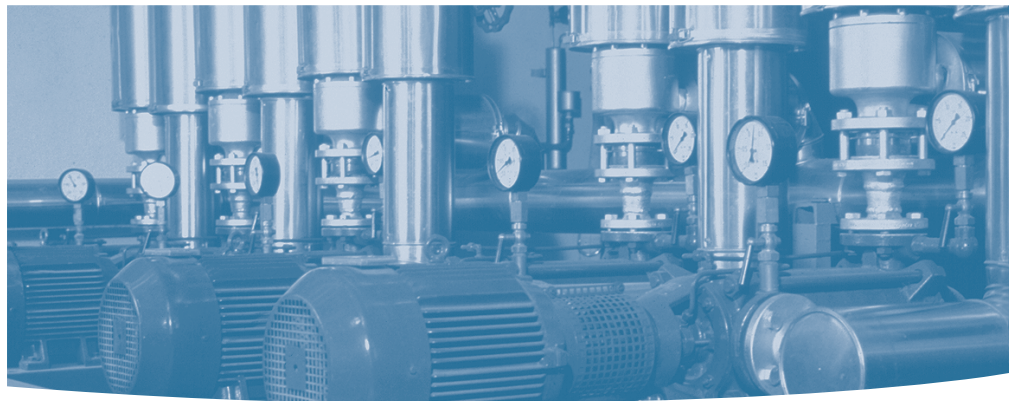

The new wide contact surfaces

They ensure optimum, uniform pressure at the flange sealing surfaces (at both inlet and outlet), so that you can rely on trouble-free plant operation.

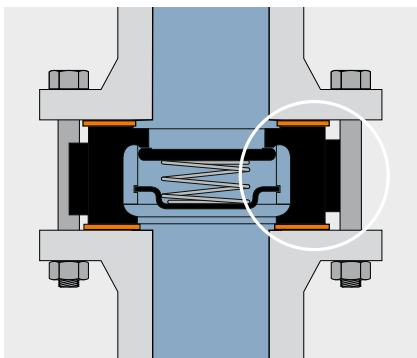
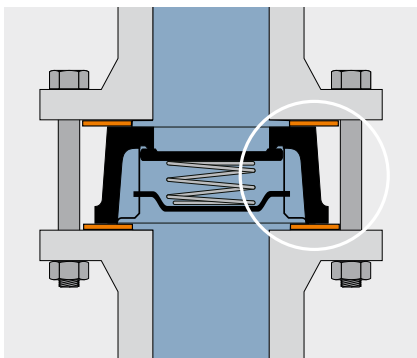

Standard antistatic connection

Antistatic connections are demanded, especially in the chemical industry, for certain parts of the plant to prevent any accumulation of static charge. The RK 86/86A range for DN 15–100 (1/2–4") with the standard threaded hole meets this requirement. For the DN 125–200 (5–8"), this threaded connection is provided on request.



The benefits in detail

- 1. Low wear**
through assured contact on two ribs
- 2. Cost savings**
through the long extension of service life
- 3. Better guidance of the valve disc**
through the four guide ribs integrated into the body
- 4. Optimum tightness**
through the new wide contact surfaces
- 5. More reliability**
through standard threaded antistatic connection
- 6. Easy installation**
through the simple body centering
- 7. Lower inventory costs**
through the more versatile range of applications
- 8. For all standards**
meets DIN/EN, ASME and BS standards



GESTRA DISCOCHECK® Dual-Plate Check Valves BB

Designed for lightness and low resistance

These GESTRA check valves are of the wafer type with short overall lengths. The reduced weight offers significant advantages for transport, stockkeeping and installation. All three basic types BB, CB and WB are characterized by excellent hydrodynamic properties.

Dual-plate check valves BB

DIN range

- DN 50–1000, PN 6–160
- ▶ Wafer-type valves
- ▶ Diameter to suit DIN EN flanges
- ▶ Short overall length to EN 558, series 16 (K3) for nominal pressures up to and including PN 63, higher pressures in accordance with API
- ▶ Metal-to-metal or soft seat (O-rings)
- ▶ DIN materials

ASME range

- 2–40", Class 150–900
- The dual-plate check valves of the ASME range are supplied with:
- ▶ Diameter to suit ASME flanges
- ▶ Face-to-face dimensions to EN 558, from Class 600 in accordance with API
- ▶ ASTM materials



Functional principle

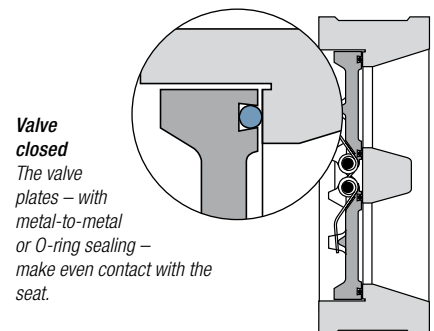

Valve closed
The valve plates – with metal-to-metal or O-ring sealing – make even contact with the seat.

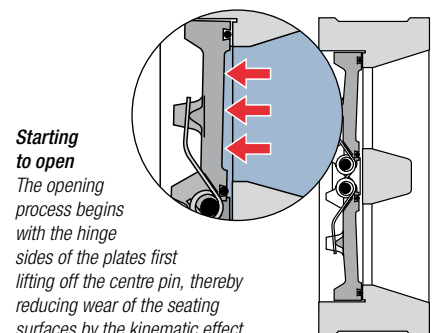

Starting to open
The opening process begins with the hinge sides of the plates first lifting off the centre pin, thereby reducing wear of the seating surfaces by the kinematic effect.

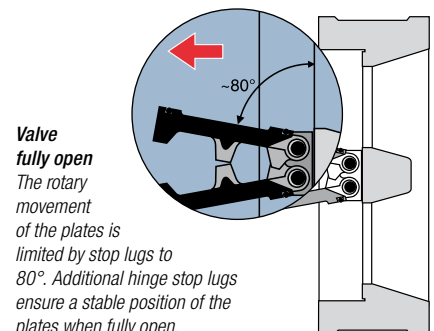

Valve fully open
The rotary movement of the plates is limited by stop lugs to 80°. Additional hinge stop lugs ensure a stable position of the plates when fully open.

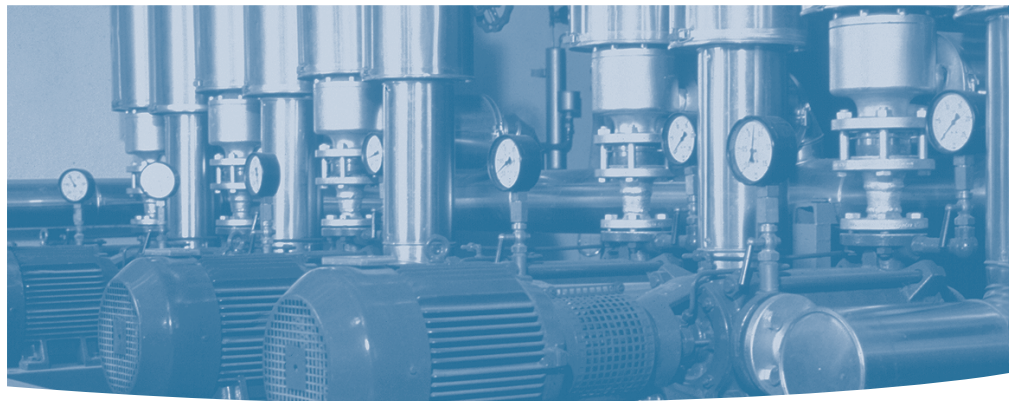

Product range

Type	Nominal pressure	50 2"	65 2 1/2"	80 3"	100 4"	125 5"	150 6"	200 8"	250 10"	300 12"	350 14"	400 16"	450 18"	500 20"	600 24"	700 28"	
BB 11 G / 21 G	PN 6																
12 G / 22 G	PN 10																
14 G / 24 G	PN 16																
BB 12 C / 22 C	PN 10																
14 C / 24 C	PN 16																
15 C / 25 C	PN 25																
16 C / 26 C	PN 40																
17 C	PN 63																
18 C	PN 100																
19 C	PN 160																
BB 12 A / 22 A	PN 10																
14 A / 24 A	PN 16																
15 A / 25 A	PN 25																
16 A / 26 A	PN 40																
17 A	PN 63																
18 A	PN 100																
19 A	PN 160																
BB valves with anti-corrosion lining																	
BB 11 G / 21 G	PN 6																
12 G / 22 G	PN 10																
14 G / 24 G	PN 16																
11 G / 21 G	PN 6																
12 G / 22 G	PN 10																
14 G / 24 G	PN 16																

All products available as DIN/EN or ASME range. Nominal sizes 800, 900 and 1000 in grey cast iron on request.

Optional items

- ▶ Anti-corrosion linings
- ▶ Special springs for very low opening pressures
- ▶ Springs for reduced closing times
- ▶ Dampers for solving waterhammer problems
- ▶ Hard-faced seat
- ▶ Purging plug
- ▶ Gaskets of EPDM, FPM, NBR and PTFE



GESTRA DISCOCHECK[®] Dual-Plate Check Valves BB

Valves with adjustable dampers from DN 200 (8") – 500 (20")

In complex pipeline systems, major flow decelerations may be caused when pumps are switched off or as a result of failures, leading to waterhammer and possibly disastrous consequences for the plant. Our engineers will be happy to assist you with the correct design of the dual-plate check valves for your installation.

Plant condition	Solution
1. Minor waterhammer $0 < \Delta p \leq 1$ bar	Dual-plate check valve BB, standard design.
2. Clearly audible and perceptible waterhammer $0 < \Delta p \leq 3$ bar	Dual-plate check valve BB, change of characteristic by fitting special springs. Waterhammer reduced by up to 40%.
3. Heavy waterhammer, pipework vibrating $\Delta p > 3$ bar	Dual-plate check valve BB, special design with patented dampers. Waterhammer reduced to zero.

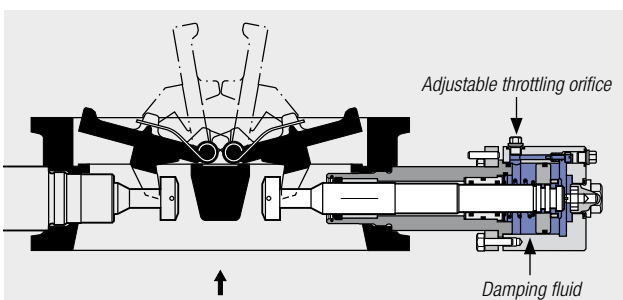
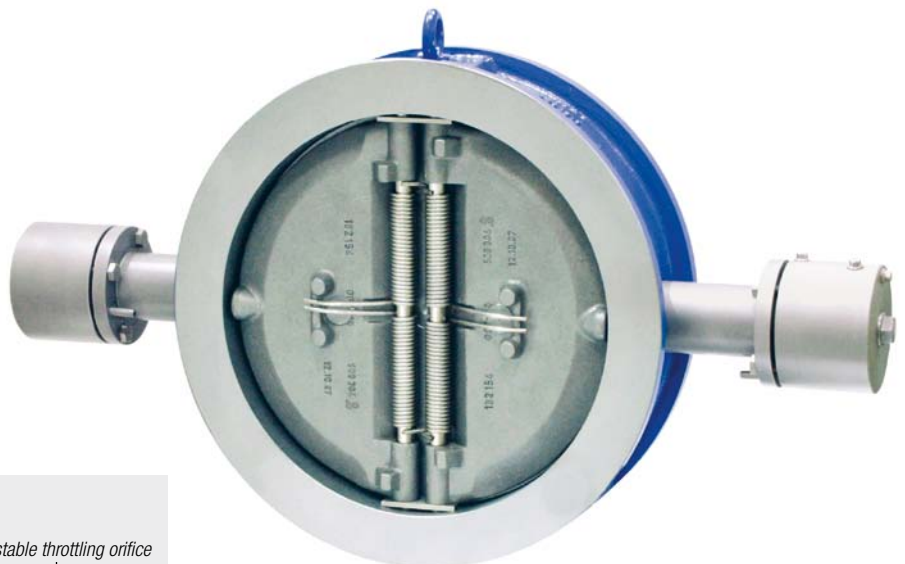

Non-Return (Check) Valves

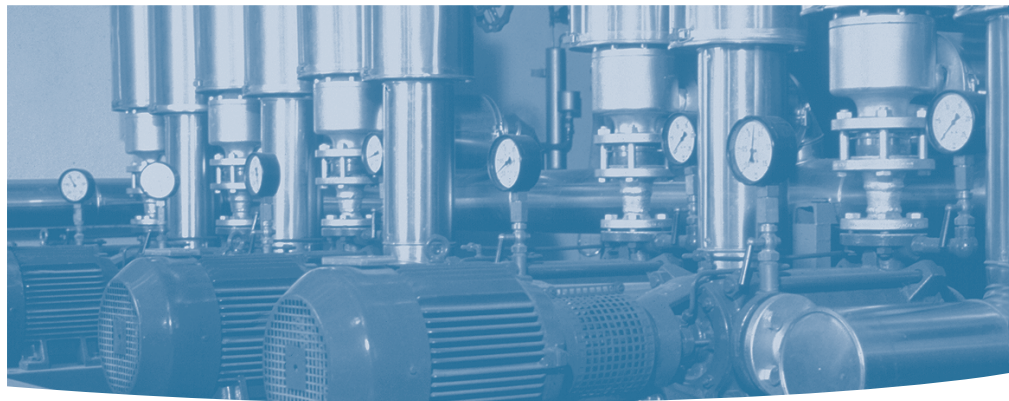

Standard materials

For applications involving liquids, gases, vapours and corrosive media, and at low temperatures, there are various materials available. As an option, DISCOCHECK® dual-plate check valves can be supplied with various soft seats.

Body	PN	DN	Application
Grey cast iron	6–16	150–1000 (6–40")	Liquids, gases, vapours,
Carbon steel	10–160	100–500 (4–20")	corrosive media
Austenitic steel	10–160	50–500 (4–20")	and low temperatures
Soft seats			
Optionally EPDM	Ethylene-propylene rubber		–40 °C to +150 °C
FPM (FKM)	Fluoro-rubber (e.g. Viton)		–25 °C to +200 °C
Optionally NBR	Acrylonitrile butadiene rubber (e.g. Perbunan)		–30 °C to +110 °C
PTFE	Polytetrafluoroethylene (e.g. Teflon)		–25 °C to +200 °C

Anti-corrosion linings

Lined cast-iron and cast-steel valves have been applied successfully for many years now in sewage works, supply and treatment plants, and for ship-building and offshore installations.

Plastic linings are used e.g. for drinking water and seawater, rubber linings for e.g. seawater and waste water.

Body/lining	Internals	PN	DN	Temperature limits
Grey cast iron / hard rubber	Bronze or austenitic steel	6, 10, 16	150–1000 (6–40")	–10 °C bis +90 °C
Grey cast iron / plastic	Bronze or austenitic steel	6, 10, 16	150–1000 (6–40")	–10 °C bis +90 °C

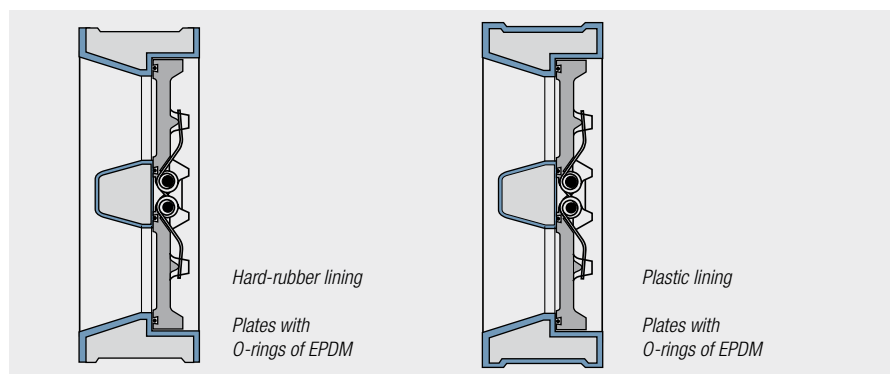



GESTRA DISCOCHECK® Dual-Plate Check Valves BB

These high-quality dual-plate check valves keep your running costs very low – by cutting the costs for pumping power and maintenance, and providing safe, low-wear operation with a long service life.

The low zeta value means that the required pump output is reduced, so that you save energy and can use a pump with lower power consumption. Stress and wear are reduced because the plate halves lift off from the centre pin before the main opening action, the plates are separately suspended (two pivots), and two springs are provided per plate half. Stop lugs at the plate halves, with additional lugs on the body, limit the opening angle to 80° and ensure a stable open position. As a result, a long and maintenance-free product lifetime is achieved.

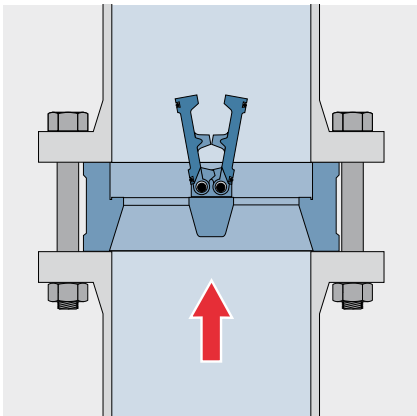

Installation

Installation position

Dual-plate check valves BB fitted with the corresponding springs can be installed in any position. In almost all installation positions, a suitable choice of springs can achieve correct adaptation to the operating conditions. Installation into vertical pipelines with downward flow is only possible with stronger springs.

Centering

By the body.

Opening pressure

The opening pressure with standard springs and horizontal flow is 7 mbar for all sizes and pressure ratings. As options, springs with an opening pressure of 2 mbar or 20 mbar can be provided if required for particular operating conditions.

Measures to be taken with turbulent flow

The turbulent flow on the pump outlet side can lead to an unstable position of the valve plates and varying opening angles. For any non-return valve, this will lead to increased wear. A stabilizing section of 5 times the nominal size should be provided at the pump outlet to protect the valve from turbulence.

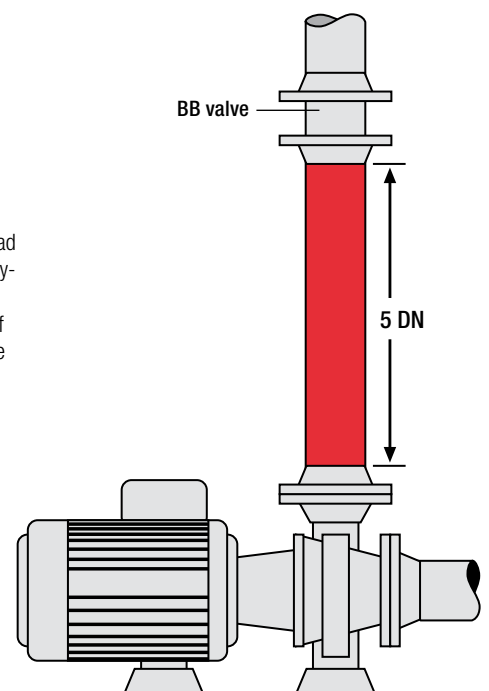

Non-Return (Check) Valves

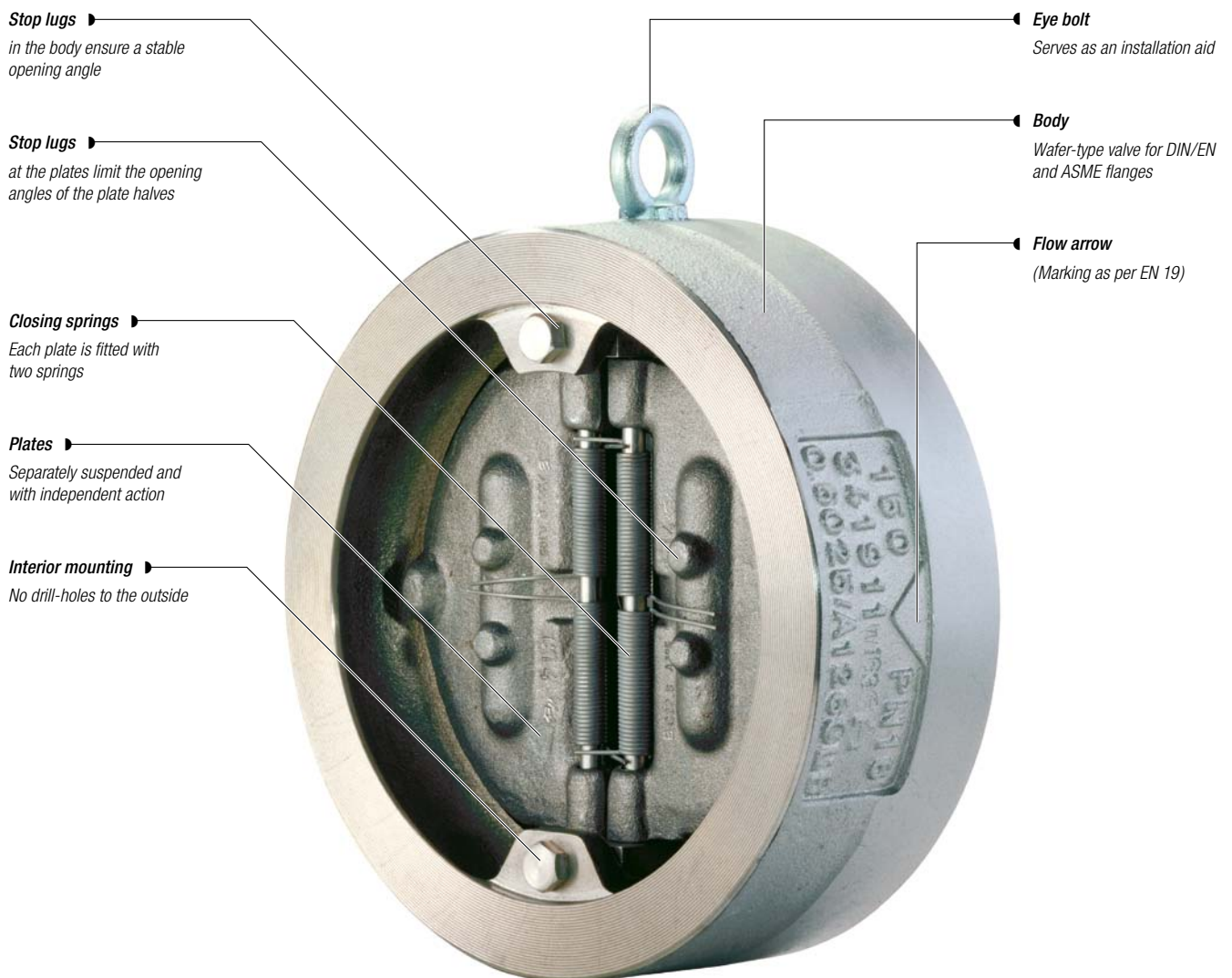
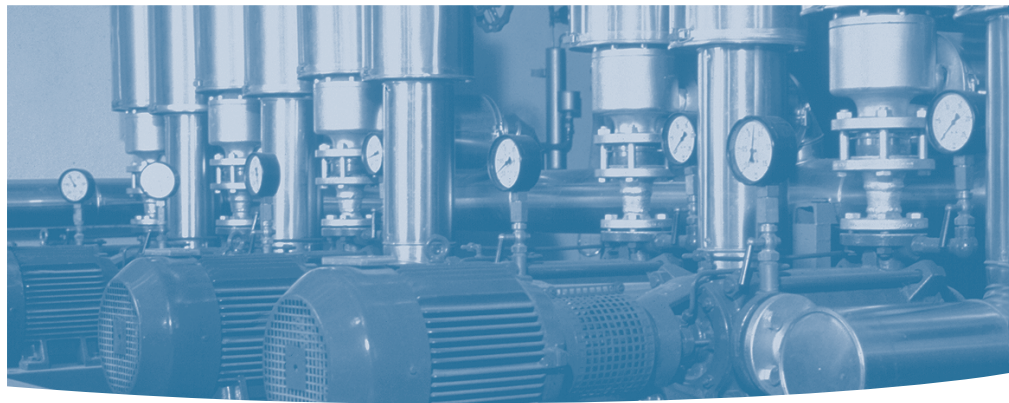



GESTRA NAF Check Valves

- ▶ Wafer-type valves for installation between flanges
- ▶ Short overall length to DIN EN 558-1, series 16
- ▶ For flanges to DIN/EN, ASME and BS
- ▶ Metal-to-metal seating
- ▶ 2 material variants (steel, stainless steel)

Installation position

NAF check valves are installed either in a horizontal line (with lifting eye on top) or in a vertical line with the flow upwards.

This check valve is characterized by excellent hydrodynamic properties, great tightness and low resistance coefficients (zeta values). Thanks to the eccentric flap hinge, low opening pressures are attained and operation is also possible without a closing spring. Stop lugs in the body ensure a defined opening angle and a stable position when fully open.

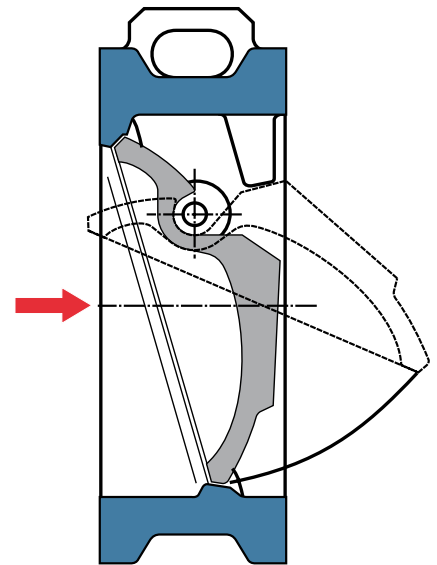

Types	PN	Spring	DN	Material	
NAF-Check 526 620	40	without	40–250 (1½–10")	Steel	For the pressure/temperature ratings and the precise material specifications, please see the relevant price list. Furthermore, we will gladly send you the product data sheets for the various types on request.
NAF-Check 526 520	25		300–1000 (12–40")		
NAF-Check 526 630	40	with	65–250 (2½–10")		
NAF-Check 526 530	25		300–1000 (12–40")		
NAF-Check 528 620	40	without	40–250 (1½–10")	Stainless steel	
NAF-Check 528 520	25		300–1000 (12–40")		
NAF-Check 582 630	40	with	65–250 (2½–10")		
NAF-Check 528 530	25		300–1000 (12–40")		

Non-Return (Check) Valves

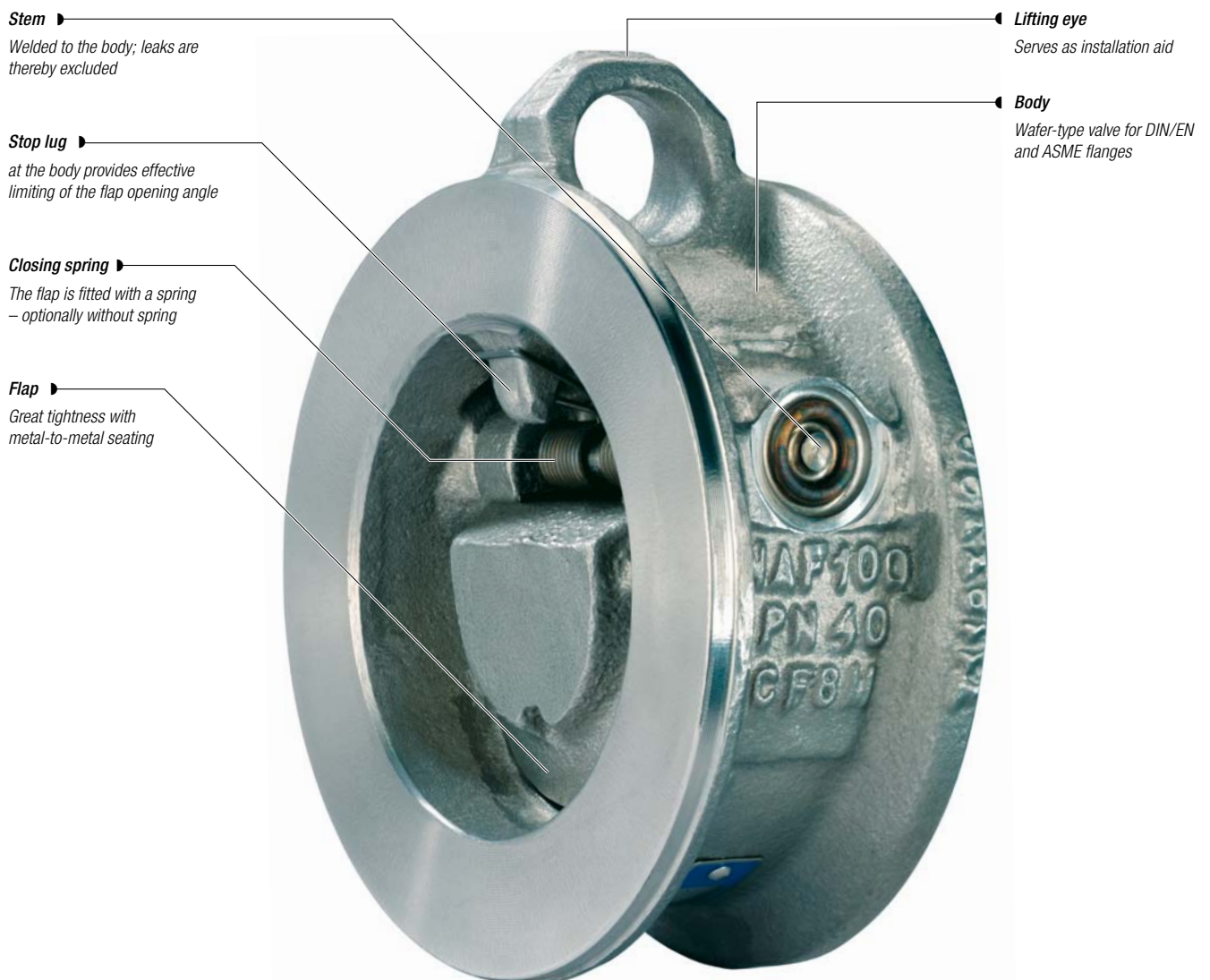
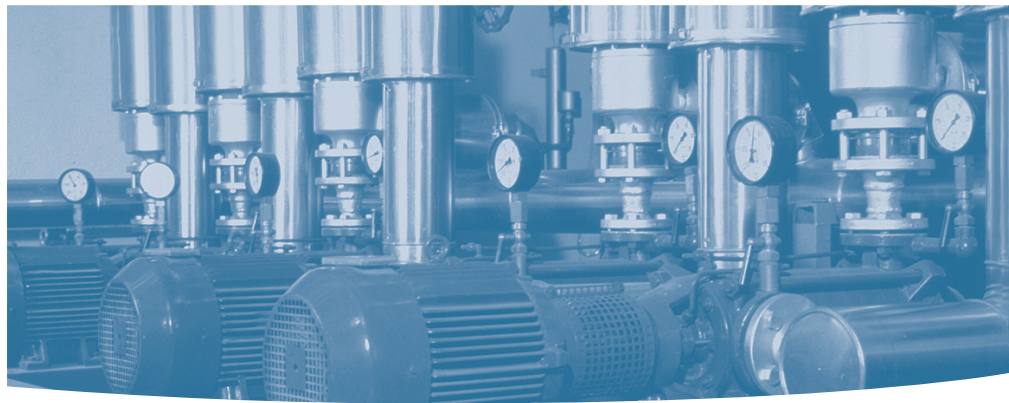



GESTRA DISCOCHECK® Swing Check Valves CB and WB

Swing check valves CB

- ▶ DN 50–300 (2–12"), PN 6–40
- ▶ DIN/EN materials

Body

- ▶ Wafer-type valve with short overall length
- ▶ Valve centred by body
- ▶ Eye bolt for ease of installation

Shut-off

- ▶ Circular flap
- ▶ Metal-to-metal or soft seat with recessed O-ring

Closing springs

- ▶ Flap with two bow springs

Opening angle

- ▶ Limited to 60° by stop lugs at the flap hinge

Special variant CB 14

- ▶ DN 50–300 (2–12"), PN 6–16

Body

- ▶ Wafer-type valve with short overall length
- ▶ Valve centred by body
- ▶ Eye bolt for ease of installation

Shut-off

- ▶ Circular flap
- ▶ Soft seat (NBR)
- ▶ Particularly suitable for dirty media

Without closing spring

- ▶ With integral synthetic rubber hinge

Opening angle

- ▶ Limited by the pipe wall

Swing check valves WB

- ▶ DN 50–300 (2–12"), PN 10/16
- ▶ DIN/EN materials

Body

- ▶ Wafer-type valve with short overall length
- ▶ Valve centred by outside of body
- ▶ Eye bolt for ease of installation

Shut-off

- ▶ Circular flap
- ▶ Flange sealing surface: soft seat with recessed O-ring

Without closing spring

- ▶ With metal hinge

Opening angle

- ▶ Limited to 60° by a stop lug in the body



All CB types can be sandwiched between pipe flanges to DIN/EN, BS and ASME. The WB types are available with body diameters to suit DIN flanges for PN 10/16.

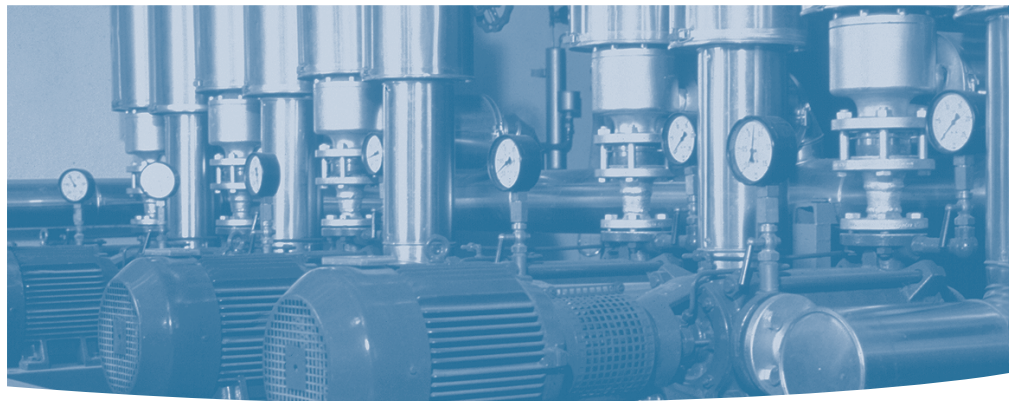

Installation

Installation position

The CB and WB valves are mounted in horizontal pipelines (with flap hinge or eye bolt on top) or in vertical pipelines with upward flow.

Installation downstream of pumps

Turbulent flow on the pump outlet side causes an unstable position of the flap, varying opening angles and hence increased wear.

Proposal A

A stabilizing section on the pump outlet side protects the swing check valve installed downstream of the pump from turbulence.

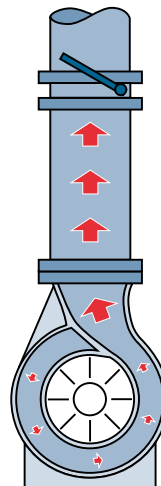

Proposal B

If the valve is fitted directly to the pump without a stabilizing section, the position of the flap's centre of rotation is of the utmost importance to enable trouble-free operation.

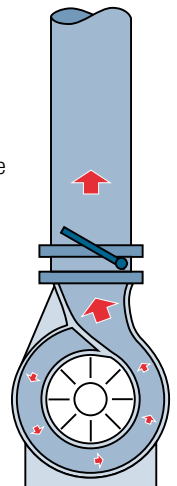

Type	Nominal pressure	Nominal sizes DN (50/65/80/100/125/150/200/250/300) (2" / 2½" / 3" / 4" / 5" / 6" / 8" / 10" / 12")
CB 24 S	PN 6/10/16	Body cast bronze / internals bronze: -200 to +90°C or without springs -200 to + 250°C. Without springs and with soft seat of NBR: -30 to +110°C
CB 26	PN 6/10/16/25/40	Steel / austenitic steel; from DN 150 (6") steel/SG iron: -10 to +350°C
CB 26 A	PN 6/10/16/25/40	Body and flap of austenitic steel: -10 to +450°C
CB 14	PN 6/10/16	Body of steel / flap of NBR: -10 to +110°C
WB 24 S	PN 10/16	Bronze/bronze: -10 to +110°C
WB 26	PN 10/16	Steel/steel: -10 to +110°C
WB 26 A	PN 10/16	Austenitic steel / austenitic cast steel: -10 to +110°C



Selection and Sizing of Check Valves

It is very important to choose the correct non-return valve for the application, and to adapt it optimally for the plant, in order to prevent clatter and premature wear.

A check valve provided with a spring or counterweight commences opening when a certain static pressure differential – pressure upstream minus pressure down-stream of the valve – has been established. This produces an opening force (pressure differential x cross-sectional area of valve), acting against the closing force. When the opening force outbalances the closing force, the valve element is opened (opening pressure). The necessary opening pressure depends on the spring tension or the weight of the counterweight, the position of installation and the size of the check valve.

On start-up of a plant, first a static pressure will build up between the pressure generator and the check valve. Once the opening pressure has been reached and exceeds the closing force, the volume

flow begins. As a consequence, the pressure upstream of the check valve drops, so that the closing force once again outbalances the opening force, causing the valve to close. This process will repeat itself until the volume flow is large enough so that, because of the additional dynamic pressure differential, the closing force is no longer great enough to close the valve.

Depending on the volume flow, the check valve opens either completely or only partly. During partial opening, i.e. at a reduced volume flow, clatter may occur. This is produced by the impact of the valve disc, cone or flap onto the seat. It is possible that, instead of clatter, a high-frequency humming tone is heard. An incessant noise is a sure sign of check valves sized too large; the valve was not chosen optimally to match the requirements of the plant. The possibility of using a valve with a smaller nominal size is no longer given if the pressure drop at full load would become too great.

Sometimes, the noise can only be heard during start-up or shut-down, or only at partial load. Then the valve is oversized only for these operating phases, and it might be possible to solve the problem by reducing the closing force, for example by using a weaker spring or a reduced counterweight. It may even be possible to use a valve without any spring at all – in vertical pipelines with upward flow.

Noise is most frequently noticed in hot-water heating installations. In this case, it is advisable to use check valves with a plastic disc/cone, e.g. the GESTRA DISCO® non-return valve RK 70.

Degree of opening of a spring-assisted check valve as a function of volume flow

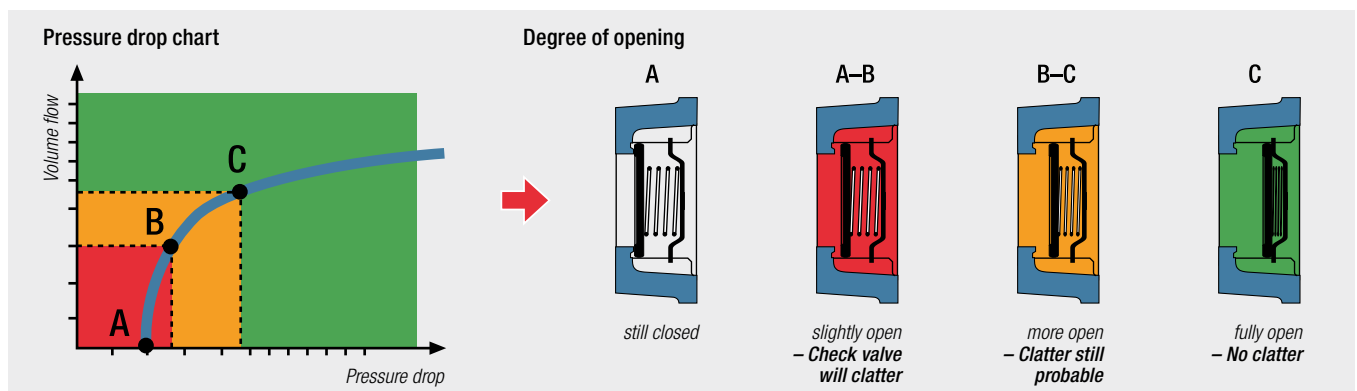

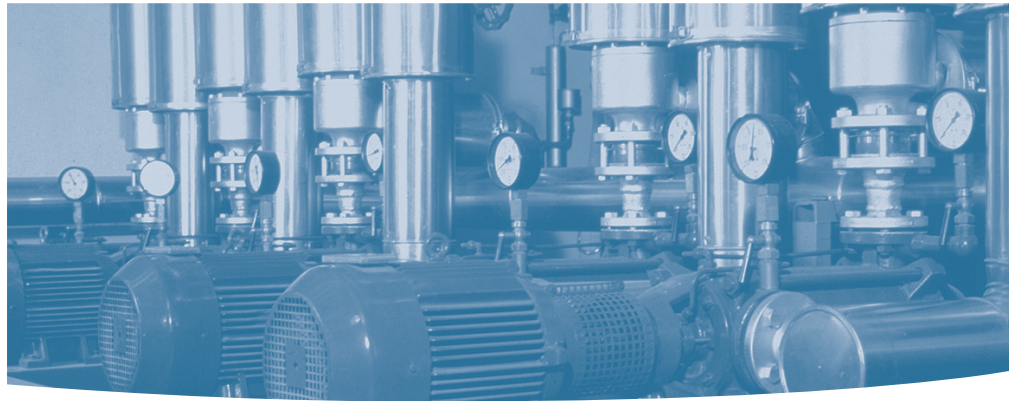

A few application examples

Here are a few examples for application using the non-return valves from our product range. If you need further support for your particular requirements, we will be happy to assist.

RK 86 (up to DN 100): solvents; coolants, cooling water; steam condensates; neutral, alkaline and weak-acid saline solutions; ammonia and ammonium hydroxide; caustic soda up to 20%; boric acid, fatty acids, diesel oil, heating oils

RK 86A: Pure steam* (for SIP applications); drinking water; swimming-pool water; media of the foodstuff industry* (e.g. dairies); mineral oil industry; aggressive media such as formic acid (up to 50%), acetic acid, caustic soda (up to 50% and 50°C), phosphoric acid, nitric acid (up to 50%), sulphuric acid (> 95%)

RK 26A: as for RK 86A

RK 16C: Highly aggressive media such as hydrochloric acid up to 10% at room temperature, sulphuric acid in all concentrations up to 50°C, formic acid and nitric acid in all concentrations, bleaching lye, chloroacetic acid, chlorosulphonic acid, chlorine

RK 49: Applications at high pressures: steam, condensate, hydraulic oil

RK 70: Heating systems, air handling

RK 41 (up to DN 100): Heating installations and district heating plants, cooling water, mineral oils, gases

MB 14: Heating plants, drinking water, cooling water



* For these applications, please order as pickled version

GESTRA dual-plate check valves BB downstream of bilge pumps



GESTRA AG

Münchener Str. 77, D-28215 Bremen
P.O. Box 10 54 60, D-28054 Bremen
Telephone +49 (0) 421-35 03-0
Telefax +49 (0) 421-35 03-393
E-mail gestra.ag@flowserve.com
Internet www.gestra.de

